

Fixturlaser NXA Pro



Welcome to our world.

Since the very beginning in 1984, ELOS Fixturlaser has helped industries throughout the world to achieve more profitable and sustainable production. We have reached where we are today by having the courage to think beyond the norm and follow slightly unconventional paths. We have had the courage to make mistakes and find new directions. Through our resolve, ambition and knowledge we have become a global player and a leader in innovative, user-friendly shaft alignment.



TPS



TRUE POSITION SENSING

- Live Values during Adjustment
- VertiZontal Moves = Measure Once, Move in Two Directions
- Both Shaft Positions Monitored Simultaneously

GRASP



GRASP

- Icon Based – Adaptive User Interface
- Touch Screen
- OmniView

AI



ALIGNMENT INTELLIGENCE

- 2nd Generation Sensor –
Allows for High Repeatability
- All Digital System
- Unparalleled Signal Control

Adaptive User Interface

Fixturlaser NXA Pro will guide you throughout the measurement, step by step.



Start



Enter Dimensions



Select Tolerance



Measure



Evaluate Results



Correcting Vertically



Correcting Horizontally



Re-measure



Documentation

Fixturlaser NXA Pro

This is a masterpiece in usability - bringing the latest technology from the video gaming world and smartphone developments to the industries' shop floors. Since the introduction in the mid 90's, we have used and refined our well proven icon driven graphical user interface.

This combined with a durable touch screen to make the precision alignment task as easy and quick as possible, also for the occasional user with the Fixturlaser NXA Pro we have improved the usability even further with the OmniView function – a state-of-the-art solution eliminating any doubt on how to adjust the misaligned machine. OmniView shows the machine on the screen exactly as you see the real machine regardless of where you are positioned.

The Fixturlaser NXA Pro display unit is rugged, rubber coated aluminum IP65 sealed, and ready for any alignment job. Battery capacity is well beyond the normal workday and a Quick-charge function to make it ready for the night shift.



Fixturlaser NXA Pro Sensor Units

As pioneers in using CCD technology for precision alignment, we are proud to present the Fixturlaser NXA Pro with the second generation of scientific grade sensors. This sensor technology combined with dual high-end inclinometers, and a gyroscope in each sensor unit, makes this compact unit the most accurate and precise sensor of its kind on the market. New algorithms, a new very compact and stable housing, and an unparalleled power management, and you have an unbeatable solution for precision alignment even in the roughest conditions.

These sensors are powered through the built-in batteries and communicate with the display unit over Bluetooth. Wireless communication is preferred in most cases, but optional wires are available. The built-in gyroscopes facilitate the alignment of vertically mounted machines.



Features Fixturlaser NXA Pro

OmniView

The OmniView function shows the machine from the same side as the user is positioned. Thanks to the built-in gyroscope the Fixturlaser NXA Pro is capable of keeping track of both you and the machine!



VertiZontal Moves

If the machine is misaligned, you will be recommended to go to a shims result view. The Fixturlaser NXA Pro calculates how much you need to remove or add shims in order to correct the machine vertically. When moving on to horizontal correction, the system goes live and will deliver real time values during the adjustment phase. No remeasurements in between adjustments are necessary, as you are never in doubt of the machine's true position.



Sensor technology

We have chosen to use CCD technology in our sensors, a digital technology commonly used in all digital cameras. The benefit over the older analog PSD technology is unmatched with regards to the capability of filtering and refining the measurement data. With this second generation scientific grade CCD sensor, we can now obtain an unparalleled repeatability together with outstanding results regardless of ambient light and measurement environment. With dual high performance inclinometers in each head, and the improved algorithms, we provide precision alignment at a completely new level.



Fixturlaser NXA Pro System

| | |
|--------------------------------------|---|
| Weight including all standard parts: | 7,7 kg (17 lbs) |
| Dimension: | 415 mm x 325 mm x 180 mm (16 in x 13 in x 7 in) |

Display Unit

| | |
|---|---|
| Weight: | 1,2 kg (2,6 lbs) with battery |
| Dimensions: | 124 mm x 158 mm x 49 mm (4,9 in x 6,2 in x 1,9 in) |
| Environmental protection: | IP 65 (Dust tight and protected against water jets) |
| Display size: | 6,5" (165 mm) diagonal (133 x 100 mm) |
| Gyroscope: | 6-Axis MEMS Inertial Motion Sensor with drift compensation and automatic field calibration. |
| Operating time | 10 hours continuous use (with 50% LCD backlight) |
| Battery charging time (system off, room temperature): | 1 hour charge – 6 hours operating time |

TD Units

| | |
|---------------------------|--|
| Weight: | 192 g (6,8 oz) with battery |
| Dimensions: | 92 mm x 77 mm x 33 mm (3,6 in x 3,0 in x 1,3 in) |
| Environmental protection: | IP 65 (Dust tight and protected against water jets) |
| Measurement distance: | Up to 10 m |
| Detector: | 2nd generation Ultra HD CCD |
| Detector length: | 30 mm (1,2 in) |
| Detector resolution: | 1 µm |
| Measurement accuracy: | 0,3% ± 7 µm |
| Gyroscope: | 6-Axis MEMS Inertial Motion Sensor with drift compensation and automatic field calibration |
| Operating time: | 17 hours continuous use (measuring) |

Shaft Brackets

| | |
|-----------------|---|
| Shaft diameter: | Ø 20-450 mm (3/4"-18") |
| Rods: | 4 pcs 85 mm and 4 pcs 160 mm (extendable to 245 mm) |

Fixturlaser NXA Pro Application



Horizontal Shaft Alignment

Determine and correct the relative position of two horizontally mounted machines that are connected, such as a motor and a pump, so that the rotational centers of the shafts are collinear.



Vertical Shaft Alignment

Determine and correct the relative position of two vertically/flange mounted machines that are connected, such as a motor and a pump, so that the rotational centers of the shafts are collinear.



Machine Train™ Alignment

Align a set-up of more than two rotating machines that are connected to each other.



Softcheck™

Softcheck™ checks if there is a soft foot condition, i.e. when the motor is not resting firmly on all its feet.



Target Values

Pre-set target values before starting your alignment work when you have determined the machines thermal expansion.



Hot Check™

Performing a measurement just after the machine has been shut off, and another measurement when the machine is cold. The Hot Check application is then used to compare these two measurements. The difference between the two measurements can be used as target values when shaft alignment is performed.



Machine Defined Data

Information such as entered distances, measurement method, target values and tolerances are saved in a template.



Feetlock™

Solution to solve base-bound and/or bolt-bound machines.



Memory Manager

Measurements can be organized in folders and subfolders. Single measurements and/or complete data structures can be copied to USB stick.

Fixturlaser NXA Pro System



1. Display unit 2. Fixturlaser M3 3. Fixturlaser S3 4. 2 pcs complete V-bracket 5. Ext. power cable
 6. USB cable A-mini 7. Power supply 8. USB stick 9. 2 pcs Angled universal tool 10. 2 pcs Magnetic v-bracket
 11. Magnetic base 12. Chain 8 mm 60 links L=970 mm 13. Rod kit 14. Extension fixture 15. Tape measure 5 m

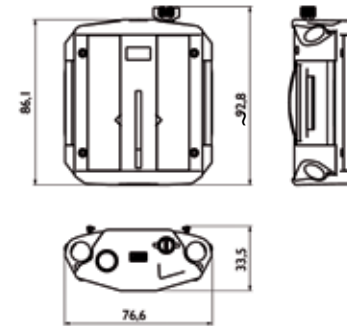
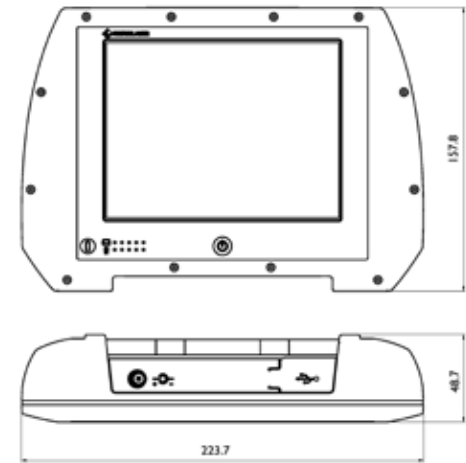

ELOS Fixturlaser is a global player and leader in developing innovative, user-friendly equipment for shaft alignment. By helping industries worldwide to become perfectly aligned, and eliminating anything that might not be, we minimize unnecessary wear and production stoppages. This will ultimately make our customers more profitable and our environment more sustainable.



P.O. Box 7 | SE - 431 21 Möndal, SWEDEN |
 Phone: +46 31 706 28 00 | Fax: +46 31 706 28 50 |
 E-mail: info@fixturlaser.se | www.fixturlaser.com |